

DIGILOCK INSTALLATION INSTRUCTIONS STANDARD BODY SURFACE MOUNT W/PULL HANDLE

BEFORE BEGINNING INSTALLATION

BEFORE INSTALLING DIGILOCK YOUR DOOR MUST BE PREPPED WITH A STRIKE PLATE (FIGURE A) AND LOCK MOUNTING HOLES (FIGURE B).

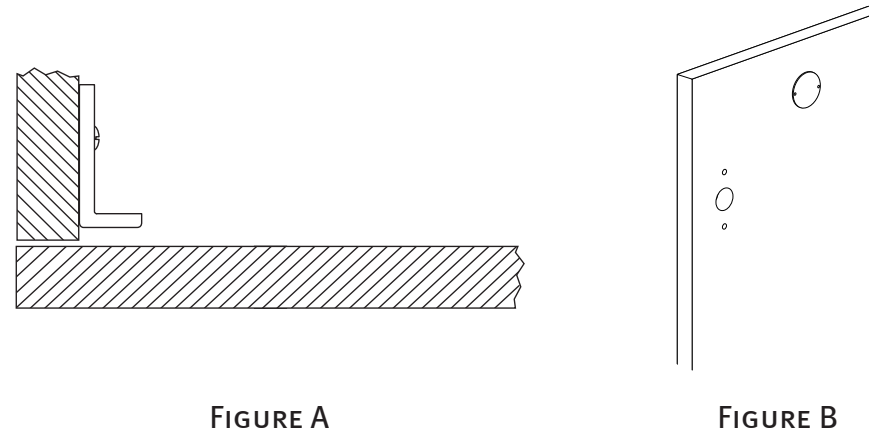

NOTE: IF YOU REQUIRE A STRIKE PLATE(S) PLEASE CONTACT YOUR DIGILOCK RESELLER OR VISIT WWW.DIGILOCK.COM FOR A LIST OF DISTRIBUTORS.

NOTE: IF YOU REQUIRE A TEMPLATE TO DRILL THE LOCK MOUNTING HOLES OR TO INSTALL STRIKE PLATES PLEASE VISIT WWW.DIGILOCK.COM OR CONTACT DIGILOCK CUSTOMER SUPPORT AT (707) 766-6000.

STEP 2

PLACE THE PIN EXTENDER (D) ON THE CONNECTED PINS OF THE REAR UNIT (F).

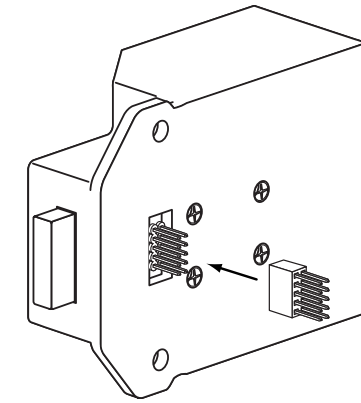

NOTE: DO NOT TOUCH THE REAR UNIT CONNECTOR PINS (MALE CONNECTOR) AGAINST ANY METAL OR OTHER CONDUCTIVE SURFACES. THIS MAY SHORT THE BATTERIES AND CAUSE DAMAGE TO THE LOCK.

INCLUDED COMPONENTS:

TOOLS REQUIRED:

PHILLIPS HEAD
SCREW DRIVER

(A) 2 - PHILLIPS HEAD SCREWS	(B) 2 - SPLIT LOCK WASHERS		
(C) 1 - PLASTIC RING	(D) 1 - PIN EXTENDER	(E) 1 - FRONT UNIT	(F) 1 - REAR UNIT

STEP 1

PLACE THE PLASTIC RING (C) ONTO THE FRONT UNIT (E).

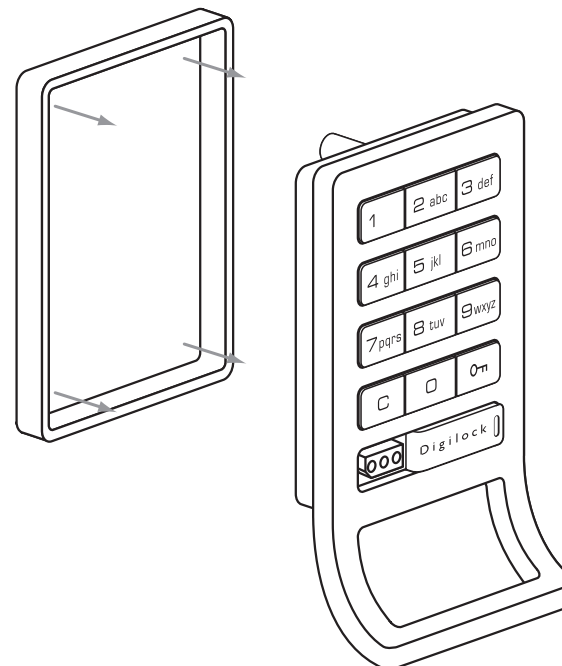

STEP 3

PLACE THE SPLIT LOCK WASHERS (B) ON THE PHILLIPS HEAD SCREWS (A) AND PLACE THE PHILLIPS HEAD SCREWS (A) THROUGH THE HOLES ON THE REAR UNIT (F) AS SHOWN BELOW.

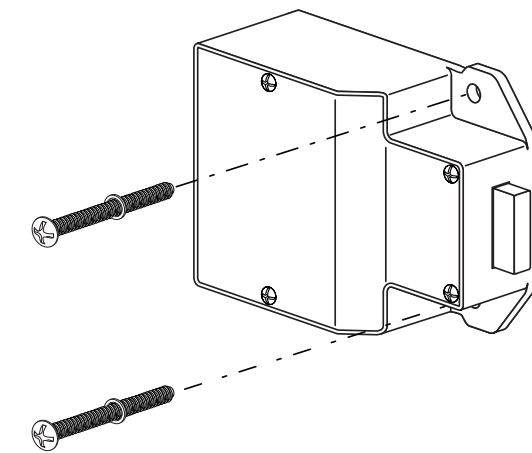

NOTE: DO NOT TOUCH THE REAR UNIT CONNECTOR PINS (MALE CONNECTOR) AGAINST ANY METAL OR OTHER CONDUCTIVE SURFACES. THIS MAY SHORT THE PINS AND CAUSE DAMAGE TO THE LOCK.

STEP 4

LOCATE THE THREE LOCK MOUNTING HOLES ON THE DOOR.

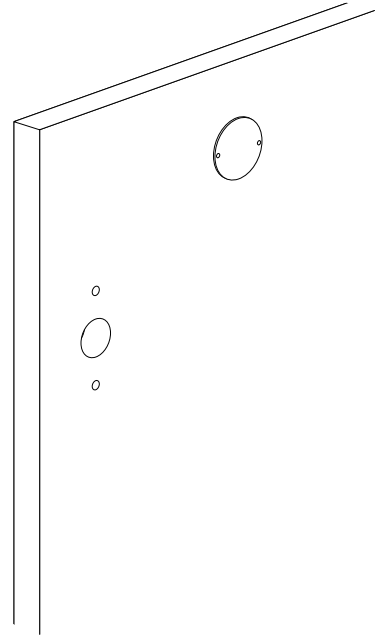

STEP 6

WHILE HOLDING THE FRONT UNIT (E) AGAINST THE FRONT OF THE DOOR, BRING THE REAR UNIT (F) AGAINST THE REAR FACE OF THE DOOR, ALIGNING THE SCREWS OF THE REAR UNIT WITH THE MOUNTING SCREW POSTS FROM THE FRONT UNIT.

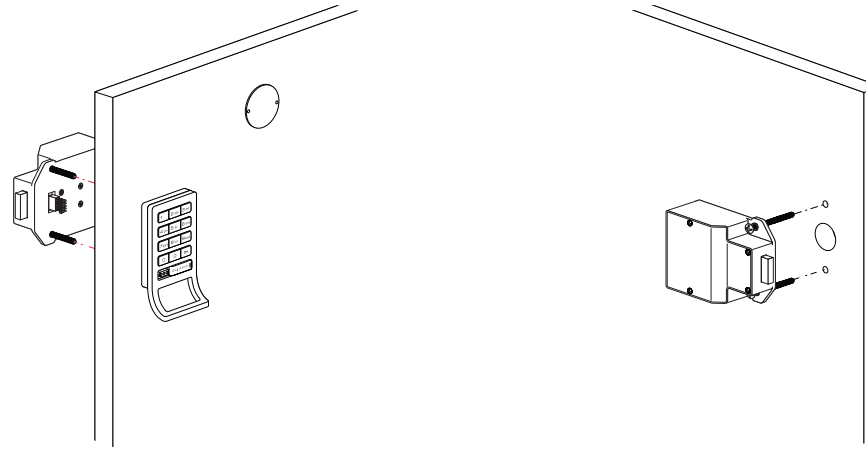

NOTE: DO NOT TOUCH THE REAR UNIT CONNECTOR PINS (MALE CONNECTOR) AGAINST ANY METAL OR OTHER CONDUCTIVE SURFACES. THIS MAY SHORT THE PINS AND CAUSE DAMAGE TO THE LOCK.

STEP 8

TEST THE OPERATION SEVERAL TIMES WHILE THE DOOR IS OPEN. CLOSE THE DOOR AND TEST THE UNIT AGAIN. MAKE SURE THERE IS NO BINDING BETWEEN THE BOLT AND THE DOOR'S STRIKE PLATE AND/OR FRAME.

TO LOCK AND UNLOCK ENTER:



NOTE: IF DURING OPERATION OF THE LOCK, THE LOCK EMITS 10 RAPID BEEPS AND 10 FLASHES OF THE LED, IT IS AN INDICATOR THAT THE BOLT OF THE LOCK IS BINDING WITH THE DOOR'S STRIKE PLATE AND/OR FRAME. IF THIS OCCURS, THE DOOR AND/OR STRIKE PLATE MAY NEED TO BE ALIGNED OR ADJUSTED.

STEP 5

PLACE THE MOUNTING SCREW POSTS OF THE DIGILOCK FRONT UNIT (E) THROUGH THE LOCK MOUNTING HOLES ON THE FRONT OF THE DOOR.

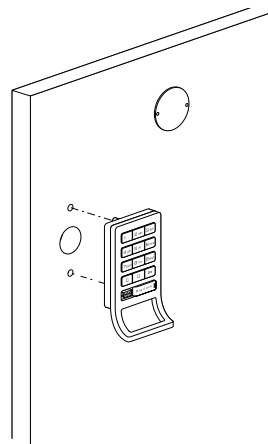

STEP 7

SLIDE THE FRONT UNIT (E) AND REAR UNIT (F) TOGETHER MAKING SURE THAT THE PINS OF THE REAR UNIT CONNECTOR ALIGN WITH THE PINS OF THE FRONT UNIT CONNECTOR AND HAND TIGHTEN THE MOUNTING SCREWS

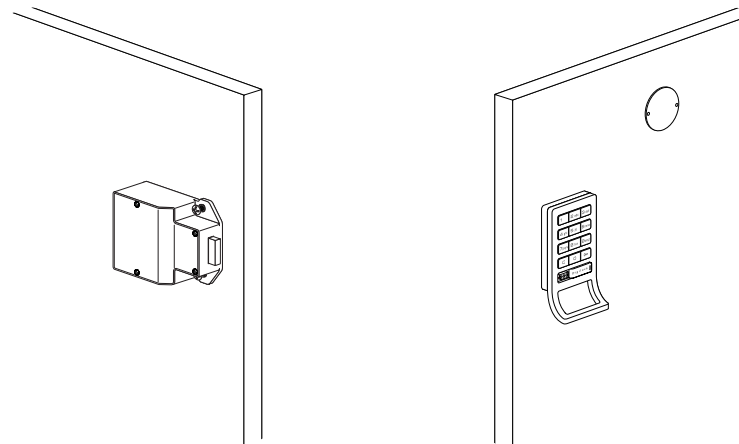

NOTE: AN AUDIBLE TRIPLE BEEP AND THREE FLASHES OF THE LED INDICATES THAT THE LOCK WAS CONNECTED PROPERLY. IF YOU DO NOT HEAR THIS BEEP, REMOVE THE FRONT UNIT, PRESS THE "C" BUTTON ON THE KEYPAD AND RECONNECT THE FRONT AND REAR UNITS.

FOR ADDITIONAL PRODUCT AND/OR PRODUCT INFORMATION

CONTACT DIGILOCK OR YOUR DIGILOCK RESELLER.

Assured Lock Tool and Supply

Phone: (888) 318-8940 or (941) 795-6960
Fax: (941) 761-9293